

# Evaluation of the Contribution of On-Site Generation to Grid and Customer Reliability

by

Tejal Kanitkar  
&  
Dragoljub Kosanovic

September 2006



**Center for Energy Efficiency and Renewable Energy**  
**University of Massachusetts**  
**160 Governors Drive, Amherst, MA 01003-9265**  
Tel (413) 545-0684 • Fax (413) 545-1027



© Copyright by CEERE

# Evaluation of the Contribution of On-Site Generation to Grid and Customer Reliability

*Tejal Kanitkar and Dragoliub Kosanovic*

## Abstract

This paper presents a method for reliability assessment of the electric grid with distributed generation providing support to the system. Evaluation of customer controlled distributed generation contribution is done for two cases; the first case analyses distributed generation wherein generation units export power to the grid. The second case analyses onsite generation wherein units handle loads at individual customer sites, thus relieving grid congestion. Reliability parameters for the distributed generation systems were obtained from data collected from existing systems that have been in operation for an extended period of time. Calculations are performed on the IEEE-Reliability Test System. The state duration sampling approach using Monte Carlo simulations is employed to evaluate the ability of the system to meet demand requirements. The impact of distributed generation on the utility controlled grid as well as on individual customer reliability is evaluated. The significance of the results obtained is discussed.

## I. Introduction

**D**ISTRIBUTED GENERATION (DG) is an electric power generation process involving units connected directly to the distribution network, or connected on the customer side of the meter [1]. For many years the number of DG units on the distribution system was limited, but new technology has increased the availability of those units with smaller ratings that are common in Combined Heat and Power (CHP). CHP is the simultaneous generation of useful electric and thermal energy. A CHP system can have a total efficiency of over 80%, while the combination of electric energy obtained from a central power plant (with an efficiency of ~35%) and thermal energy obtained from an on-site boiler (with an efficiency of ~80%) has a total efficiency of approximately 50%. Also, the liberalization of energy markets has provided a push for generation units to be introduced to distribution systems. An *Electric Power Research Institute* (EPRI) study recently concluded that by 2010, 25% of all new generation would be distributed [7].

The new electric distribution system may include DG units operating at different locations and schedules. The DG units may be operated by customers (CDG units) or by the utilities. From the utility's perspective, CDG units are completely stochastic facilities in the network, as both the operating schedules and locations are customer controlled [4]. As a result, the use of CDG in the distribution network increases the network operation complexity for the local distribution company. The advantages of DG installed on the distribution network, most often claimed by its proponents, are decrease in emissions, reduction in congestion of the electricity transmission and distribution grid, lower overall cost of energy, the improvement of electric and customer system reliability, improved power quality and increased grid security, to name a few. However, opponents claim that DG causes a decrease in electric system reliability, voltage fluctuations [2] and uncertainty of operation [3]. This paper attempts to demonstrate a method for reliability assessment of the electric distribution system with Distributed Generation installed under two scenarios; (i) relatively larger systems supplying power to the customer and exporting power to the grid and (ii) CDG systems - relatively small systems handling loads for individual customers. The goal is to evaluate the significance of their contribution to existing power system reliability.

Different DG owners will have different strategies for operating their DG units and accordingly, the process of turning on and off each DG unit will be a random process for the distribution utility. This will result in a random contribution of that DG to the system power capacity. Consequently, the overall system capacity will vary randomly and the determination of this randomly varying capacity will require proper modeling of the changing operating states of the system [4].

“Reliability”, as normally applied to power distribution means availability and continuity of service to the electric consumer. In this analysis, Loss of Energy Expectation (LOEE - MWh/yr) at the generation level for the entire

---

This work was supported in part by the U.S. Department of Energy and the New York State Research and Development Authority under Grant S32500000300000

system and Average Energy Not Supplied (AENS - MWh/customer/year) at the distribution level for individual customers are the two reliability indices used to evaluate the system.

A simulation technique known as the Monte Carlo method is used to generate an operating history based on the measured parameters (mean time to failure, mean time to repair etc.) for a power system. The reliability of the system is then determined using available load data and power generation data.

The adequacy assessment for power systems has been studied considerably in the literatures [5] and [6] and the adequacy assessment for distributed generation systems (with random input into the system) has been performed in [7] to find the Annual Unsupplied Load (AUL). However, the analysis presented in this paper takes into consideration the measured operating characteristics of individual customers to determine DG contribution and presents results for customer reliability as well as system reliability (AENS and LOEE). The work done in this paper is presented according to the following sections. Section II presents the formulation of the problem. Section III describes the method used for reliability assessment. Section IV shows a case study of the IEEE-Reliability Test System (IEEE-RTS) along with a discussion of the results obtained and finally, Section V discusses the conclusions offered by this analysis.

## II. Problem formulation

The application of Combined Heat and Power (CHP) enables the users/customers to install electricity generation units in their facilities, and to use the waste heat from it for process requirements or space heating. This dual purpose can be achieved using various generating techniques, e.g. gas turbines, reciprocating engines, steam turbines etc. The electricity generated by these units can have a significant impact on the reliability of energy supply for that customer and also on the reliability of the existing utility controlled power system.

The problem formulation for the analysis presented in the paper is explained in this section

### A. Given

A profile for the total hourly load on the distribution system is available (the data is usually available with the utility for various zones). This is a sum of all the customer loads on a particular system. The hourly load for any customer is also available (usually monitored by the customers themselves). The substation is supplied with power by many utility-owned centralized generating units. The working parameters for these generating units can also be obtained from the utility (Mean time to failure, mean time to repair, and scheduled outage time for each unit). These parameters are used to simulate the operating history for the power system. Customers usually install DG units based on their thermal energy needs in order to maximize fuel efficiency. The reliability parameters of the DG unit will vary based on the type of its prime mover and size, e.g. as the size of the unit increases the Mean Time to Failure also increases, i.e. a larger unit is more reliable. The working parameters of the DG units are also available and depend on the size of the DG units used. The contribution in electricity generated and thermal energy supplied by the DG units depends on the process and operating needs of the users.

### B. Required

The impact of DG unit operation on total system power supply reliability and customer reliability has to be evaluated. The difference between the reliability indices before and after the implementation of DG can serve as a guide to quantitatively understand the significance of the difference made by DG to the existing system. The two Reliability indices to be evaluated are LOEE (Loss of Energy Expectation – MWh/year), which is the total load that is not supplied by the substation, and AENS (Annual Energy Not Supplied – MWh/year/customer), which is the total load that is not supplied by the substation to a particular customer.

$$LOEE = \sum_{i \in S} 8760 \times C_i p_i \quad (1)$$

Where  $i$  denotes the state of the system (whether the system is running or is down or has failed),  $C_i$  is the loss of load for system state  $i$ ,  $p_i$  is the probability of system state  $i$ , and  $S$  is the set of all system states associated with the loss of load (e.g. system in down state or failed state) [6].

$$AENS = \frac{ENS}{\sum_{i \in R} N_i} \quad (2)$$

Where  $i$  denotes the point at which load is experienced (a load bus), ENS is the total Energy Not Supplied,  $N_i$  is the number of customers at load point  $i$ , and R is the set of load points in the system.

### C. Approach

The operation and electric supply contribution of the DG units within the system follow the load requirements of the customer, but their failure, restart and maintenance requirements are treated as random processes in the system. Monte Carlo simulations are used to simulate the operating histories of these DG units based on the measured reliability parameters available for the individual units in operation (Mean time to failure, Mean time to repair etc.).

The analysis is first done to evaluate the reliability of the existing distribution system without any DG units operating within it (LOEE<sub>current</sub> and AENS<sub>current</sub>). The next step is to evaluate the reliability with the DG units operating in the system (LOEE<sub>with DG</sub> and AENS<sub>with DG</sub>).

## III. Methodology For Reliability Assessment

### A. Reliability without DG

**Load Modeling** -The total load on the distribution system (Load<sub>system</sub>) and individual customer load (Load<sub>customer</sub>) for one year at least is required to conduct reliability test studies (one year's worth of load data can take into consideration seasonal variation in load, and other irregularities.). For the purpose of a realistic analysis, it can then be assumed that this load varies by 5% within the monitored load every consecutive year.

**System Modeling** – The distribution system supplies the power that has been generated by many different units (could be coal, hydro, oil, natural gas etc.). These units have varying operating cycles and can be modeled as two stage systems as shown in Fig.1.

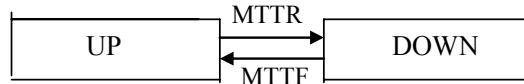

Fig.1. Two stage system model

The transition from one stage to another is determined using the parameters Mean Time to Failure (MTTF – from UP to DOWN) and Mean Time to Repair (MTTR – from DOWN to UP). For the purpose of this analysis, the State Duration Sampling Approach is used. The desired values are determined based on sampling the probability distribution of the component state duration. The operating and repair state duration distribution functions can be assumed to be exponential for continuous probability distribution functions [6]. They ensure faster convergence and less computational time with adequate accuracy. A detailed explanation of the State Duration Sampling approach is given in literature [6].

Given an exponential distribution, the sampling value of the system's state duration is

$$T_i = -MTTF \times \ln(U_i) \quad (3)$$

Where  $U_i$  is a uniformly distributed random number between [0,1] corresponding to the  $i^{\text{th}}$  component. Therefore  $T_i$  is the time taken before the component transitions from the UP state to the DOWN state. The same equation can be used with the parameter MTTR to determine the time passed before the component transitions from DOWN to the UP state. The combination of the operating states for all these units gives the total system capacity at any given hour.

The System Margin can be determined by superimposing the load curve on the power curve; i.e. if the hourly peak load on the system for all customers is subtracted from the hourly power transmitted by the substation, a system margin can be estimated. If the system margin is negative, the load exceeds the power transmitted and the station capacity is deficient in supplying the load. If the system margin is either zero or positive, the power supplied either equals or exceeds the load and station capacity is sufficient to supply the demand. System Margin (SM) can be determined using the following equation:

$$SM = P_{transmitted} - Load_{system} \quad (4)$$

If only all the negative values of the System Margin are considered, the resulting set of values could be called the Negative Margin (NM)

**Reliability Evaluation** – For the purpose of computational simplicity, the formula used for reliability index calculation for the entire system is shown below.

$$LOEE_{current} = \frac{\sum_{i=1}^N ENS_i}{N} \quad (5)$$

ENS = Total Energy not supplied (MWh) =  $\sum$ Negative Margin

N = Number of experimental simulations or the number of years for which ENS is calculated.

The reliability index AENS can be written as

$$AENS_{current} = \frac{\sum_{i=1}^N ENS(bus)_i}{N} \quad (6)$$

Here ENS (bus) is the energy not supplied to the bus or could be the energy not supplied to one customer, and depends on the hourly load experienced by that particular bus or customer.

#### E. Reliability with DG

Distributed Generation Unit Modeling - The DG system can be modeled such that there is a Generation Unit at each or some of the load buses. The generating capacities vary depending on customer requirements and installations. The CDG units for this analysis are modeled as four-stage systems shown in Fig.2.

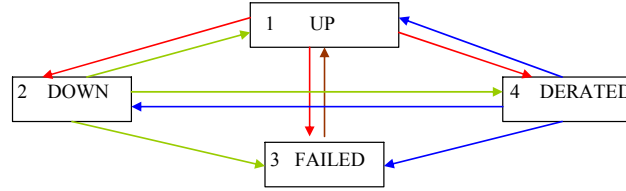

Fig.2 Four stage system model for DG units

It can be assumed that at the beginning of the simulation, the generation units are all in the UP state. The DG unit can transition to the DOWN, DERATED or FAILED states from the UP state. The UP state indicates that the customer is operating the DG unit at full generation capacity. The DOWN state is a “scheduled shut down” stage, i.e. the customer shuts down the DG unit voluntarily. The DERATED stage indicates that the DG unit is operating at derated capacity, which is a certain percentage of the full generation capacity. The FAILED state indicates that the system has encountered an unscheduled shutdown.

The operating schedules for different DG units in the system will be calculated using the State Duration Sampling method.

System Modeling –The new energy capacity of the system (for the case where the DG units export power to the grid) or the reduced load experienced by the system (for CDG units which do not export power to the grid) is calculated using the following equations.

$$P_{total} = P_{transmitted} + P_{DG} \rightarrow \text{for Units Exporting Power} \quad (7) \quad Load_{new} = Load_{old} - P_{DG} \rightarrow \text{for CDG Units} \quad (8)$$

As explained in section III A, the System Margin (SM), Negative Margin and the new reliability indices (LOEE<sub>with DG</sub> and AENS<sub>with DG</sub>) should now be calculated using the new energy capacity or new load of the system.

## IV. Case Study

The generation and distribution system under consideration is modeled from the IEEE-Reliability Test System (IEEE-RTS) with 32 different generating units supplying the load on the system. The total capacity of the system is 3405 MW when all units are running. For a more realistic model, in this analysis it is assumed that for every iteration, the system capacity at any given hour varies randomly within 5% of its nominal capacity at that particular hour. The total load on the system is also modeled based on data for the IEEE-RTS with a peak load of 2850 MW. It is assumed that for each consecutive iteration (year), the load varies by about 10% (to achieve real world uncertainties in the model) for any given hour.

In the first phase, reliability analysis is done for the system and each customer, with the system power represented only by the electricity generated by the centralized generation units (units of the IEEE-RTS system). In the second phase, the analysis is done for the case where the DG units are operational within the system and either exporting power to the grid or handling individual loads for customers (Figure 3).

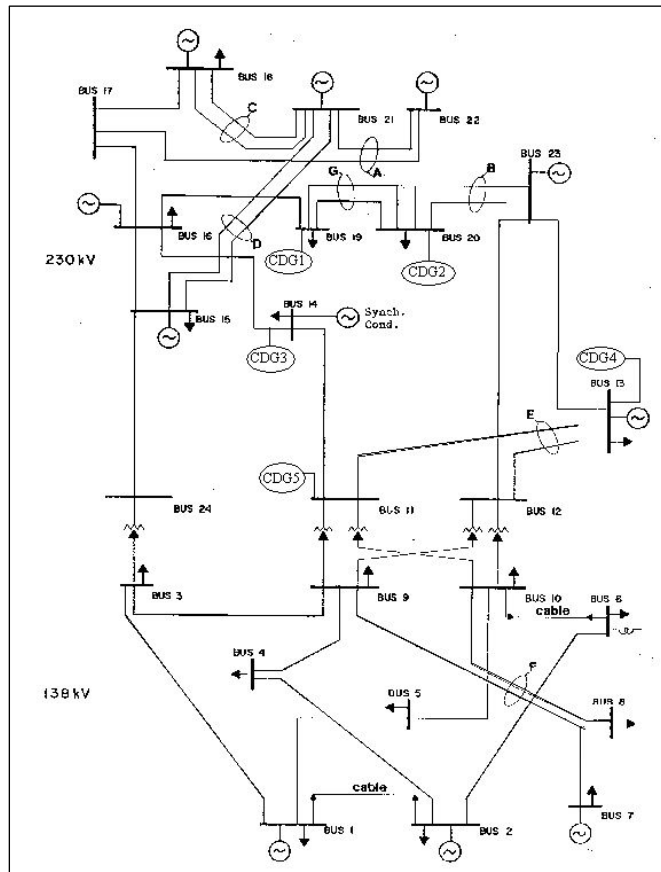

Fig. 3: IEEE – Reliability Test System

For the first three customers, the actual electric and thermal load profiles were obtained during various on-site energy assessments and used as an inserted into IEEE-RTS system. The DG unit at bus 19 controlled by Customer 1 has a capacity of 0.7 MW.

LOEE is calculated using the total load and the total power capacity. For AENS, the analysis is done assuming 3 different CDG units (smaller units handling loads at individual customer sites) and 2 relatively larger DG units exporting power to the grid, within the system. The loads experienced by the 3 users in the system are given in Table I. The hourly electric and thermal load profile for Customer 3 (monitored on-site) for one week is shown in Figure 4.

TABLE I EXPERIENCED BY USERS IN EVERY SHIFT

	Load (MW)		
	Customer 1	Customer 2	Customer 3
1 <sup>st</sup> Shift	5	2	0.7
2 <sup>nd</sup> Shift	2	2	0.4
3 <sup>rd</sup> Shift	1	2	0.4
Weekends	1	2	0.1

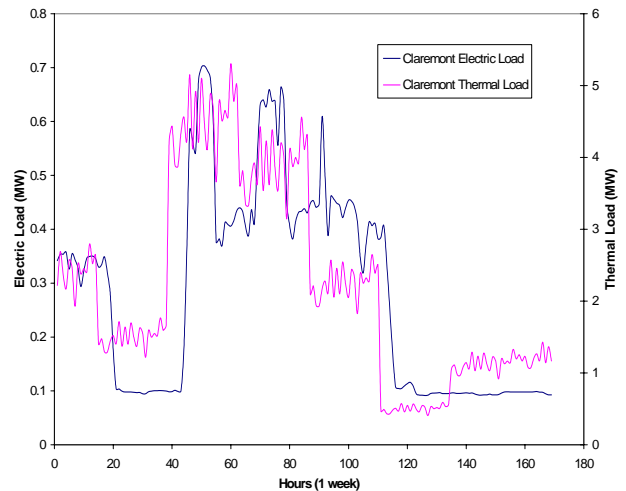

Fig.4. Hourly Load profile for Customer 3 for

one week

*Phase A* – In this phase, the substation alone represents the system capacity, and DG units are not considered. The negative margin was calculated and a sample one-year negative margin is shown in Fig.5. The annual energy not supplied to the individual customers is also calculated by taking into account only the customer load and the distribution system’s capability to supply that load.

Fig.6 shows the sample ‘Energy Not Supplied’ to Customer 1 for one year.

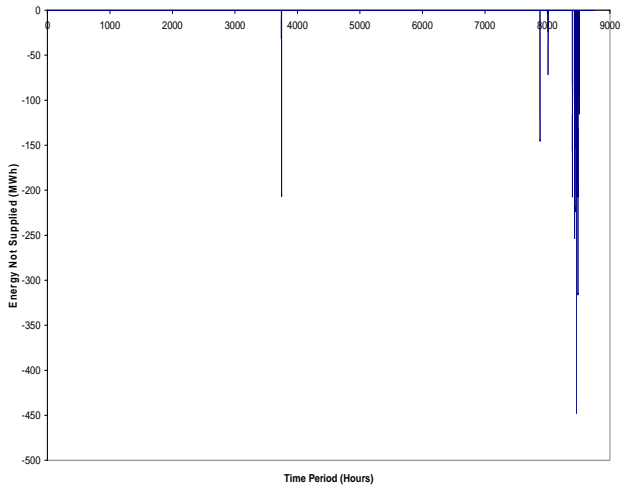

Fig.5. Negative System Margin

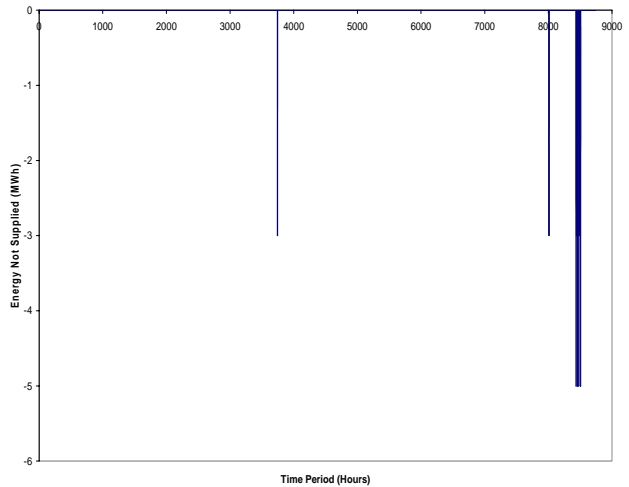

Fig.6. Negative Margin for Customer 1 for one Sample year

It is clear from Fig.5 that the system encountered a considerable number of hours when the demand was not met. However, since this negative margin seen in Fig.5 is just for one year, it cannot be used to evaluate the system, since during this sample year  $P_{transmitted}$  is considered to be a random variable. The set of calculations are repeated until the variance reduces to a reasonably acceptable number (Co-efficient of Variation = 0.01 in this case) and  $LOEE_{current}$  is calculated as explained in Section III.  $LOEE_{current}$  is estimated to be 4,405 MWh/year. Fig.7 shows the Monte Carlo convergence process.

The  $AENS_{current}$  is calculated for all three customers and is estimated to be 104 MWh/year, 57 MWh/year and 15 MWh/year for customers 1, 2 and 3 respectively. The Monte Carlo convergence process for  $AENS_{current}$  is shown in Fig. 8.

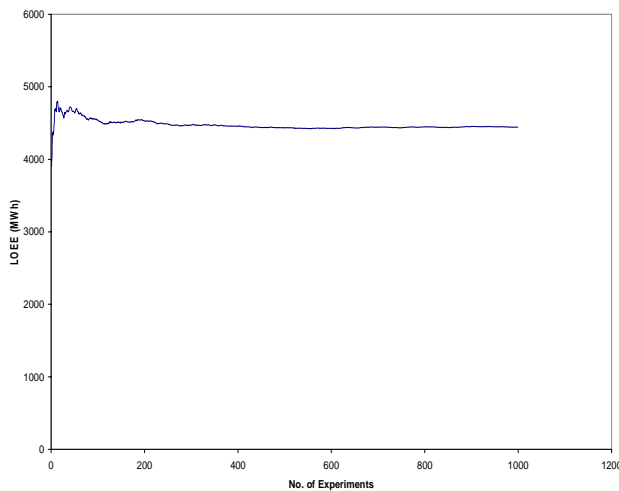

Fig.7. Monte Carlo Convergence for index LOEE

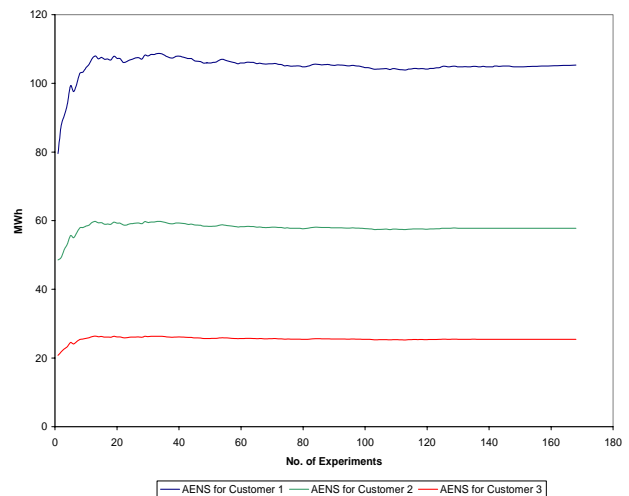

Fig.8. Monte Carlo Convergence for index AENS

**Phase B** – In this phase, the DG units operation within the system is considered. The DG units in the system that export power to the grid are assumed to be 20 MW and 10 MW respectively. These units are assumed to be base loaded; while in the UP state they generate as much power as they can and whatever is not used by the owner is exported to the grid. The reliability indices for these units are given in Table II.

MTTF, MTTR and SOF are measured (monitored) values taken from the literatures [8] and [9] for systems that have been in operation for a considerable amount of time.

For DG systems that are not exporting power to the grid, the DG unit sizes used by the customers are equal to the peak loads they experience, e.g., since customer 1 experiences a peak load of 5 MW, the combined capacity of DG units installed by customer 1 will be 5 MW. The units run at derated capacities as determined by the customer when they are needed to supply lesser loads (say in second or third shifts). The reliability indices for the CDG units are shown in Table III.

TABLE II: OPERATIONAL PARAMETERS FOR BASE LOADED UNITS

	DG Unit 1 20 MW	DG Unit 3 10 MW
MTTF (hrs)	1956	2051
MTTR (hrs)	68	66
Scheduled Outage factor (SOF - %)	2.389	1.458

MTTF is Mean Time to Failure (hrs)

MTTR is Mean Time to Repair (hrs)

TABLE III: OPERATIONAL PARAMETERS FOR CDG UNITS

	Customer 1 5 MW	Customer 2 2 MW	Customer 3 0.7 MW
MTTF	3604	3052	1627
MTTR	27.18	28	27
Scheduled Outage factor (SOF) %	1.1233	0.4715	0.174

The new reliability index for the system ( $LOEE_{DG}$ ) is calculated for the case where all the units mentioned above (Base loaded units and CDG units) are present in the system. Also the contribution of each DG unit to the system is evaluated.  $AENS_{DG}$  is calculated for the all the three customers using *equation 6*.

The results are tabulated for both indices LOEE and AENS in Table IV and Table V respectively.

TABLE IV: PERCENTAGE IMPROVEMENT IN INDEX

Unit Size (MW)	$LOEE_{current}$ (MWh/year)	$LOEE_{DG}$ (MWh/year)	% Improvement
20*	4405	4101	6.9
10*		4214	4.33
5		4332	1.65
2		4366	0.88
0.7		4376	0.65
All Units		3827	13.12

\*Are Base loaded DG units exporting power to the grid

LOEE TABLE V: PERCENTAGE IMPROVEMENT IN INDEX AENS

Unit Size (MW)	$AENS_{current}$ (MWh/year)	$AENS_{DG}$ (MWh/year)	% Improvement
5 MW (Customer 1)	104	45.69	56.06
2 MW (Customer 2)	57	15	73.68
0.7 MW (Customer 3)	15	0.928	93.8

## V. Conclusions

From the results obtained above it can be concluded that DG units enhance the reliability of the system, even though individual reliabilities of the DG units are not attractive. The system reliability before installation of distributed generation was 99.971% and increased to 99.98% after installation of the DG units. The application of Combined Heat and Power (CHP) can further justify the implementation of on-site generation, since the waste heat from electricity generation can be used to supply process or space heating requirements, thus considerably reducing energy costs incurred by the customers. Use of the reliability assessment technique shown in this paper can help to evaluate distributed generation as a quick and reliable solution to an expected increase in demand in the future. This is true for both situations considered in this paper, i.e. DG units exporting power to the grid or just supplying individual loads without being connected to the grid.

## VI. References

- [1] T. Ackerman, G. Anderson and L. Soder, "Distributed generation: A definition", *Electrical Power Systems, Res.*, vol.57, pp. 195-204, 2004.
- [2] H. Lee. Willis, Walter G. Scott, *Distributed Power Generation*, New York: Basel, 2000.
- [3] F.V.Edwards, G.J.Dudgeon, J.R.McDonald and W.E.Leithhead, "Dynamics of distribution networks with distributed generation", *Proc. IEEE Power Eng. Soc. Summer Meeting*, pp. 1032-1037, 2000.
- [4] Walid El-Khattam, Y. Hegazy, M.M.A. Salama, "Stochastic Estimation of the Contribution Levels of Customer Operated Distributed Generation", *IEEE Power Eng. Soc. general meeting*, Denver, Colorado, 2004.
- [5] Roy Billinton, Ronald Allan, *Reliability Assessment of Large Electric Power Systems*, Boston/Dordrecht/Lancaster: Kluwer, 1988.
- [6] Roy Billinton, Wenyan Li, *Reliability Assessment of Electric Power Systems Using Monte Carlo Simulations*, New York: Plenum, 1994.
- [7] Y.G.Hegazy, M.M.A.Salama and A.Y.Chikhani, "Adequacy assessment of distributed generation systems using Monte Carlo Simulation", *IEEE Transactions of Power Systems* Vol. 18, Feb. 2003, pp.141-143
- [8] Executive Summary Report - *Distributed Generation Operational Reliability and Availability Database*, Submitted to: Oak Ridge National Laboratory, 2004.
- [9] Mark Gerrish, "Reliability Issues in Combined heat and Power", Masters Thesis, Dept. of Mechanical and Industrial Engineering, Univ. of Massachusetts, Amherst, 2006